

PREPARATION

Knowing the Headset Layout

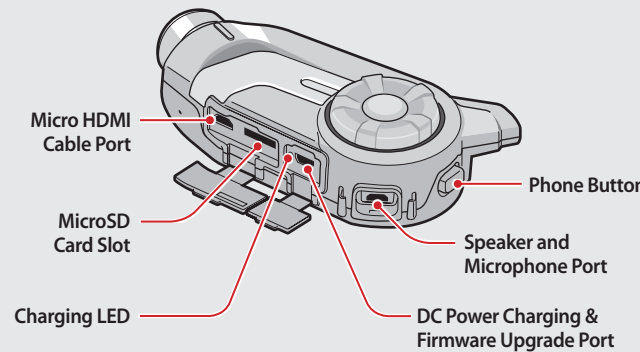

Installing the Headset

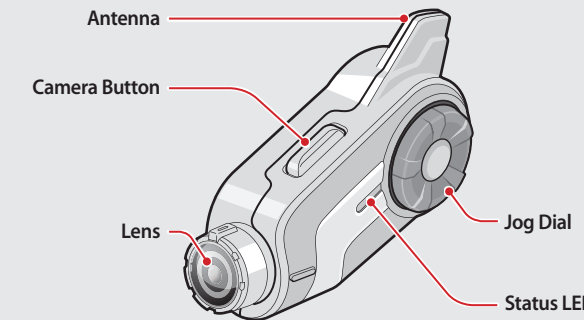
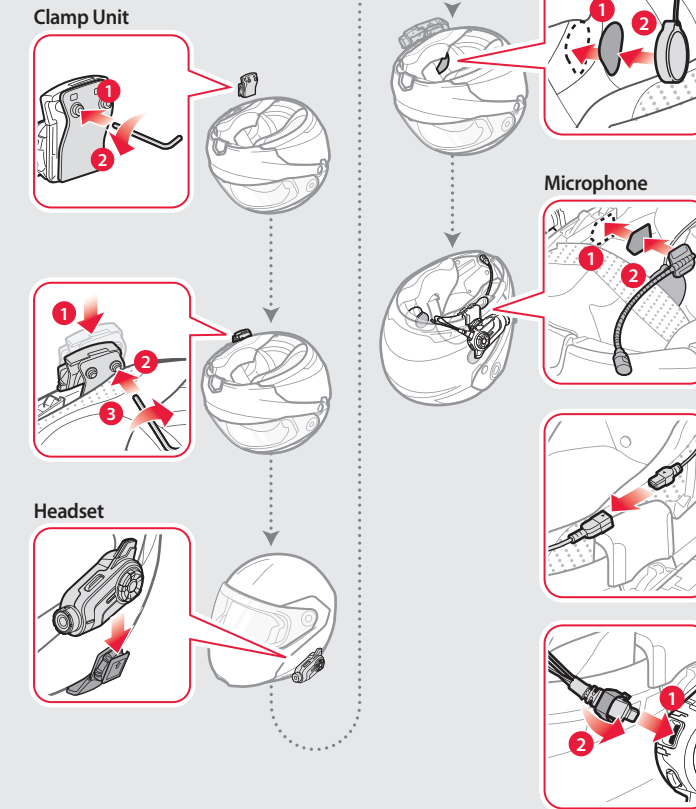

BASIC OPERATION

Operating the Buttons

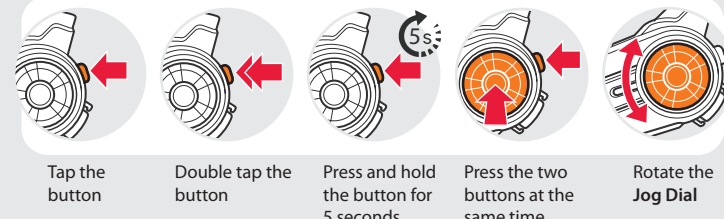

Turning On/Off the Headset

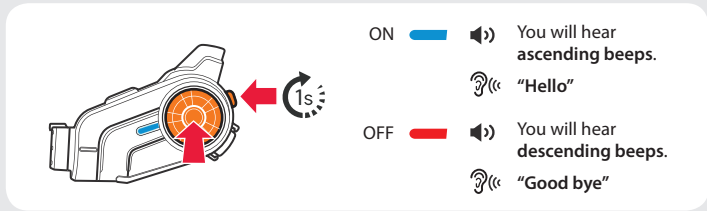

Adjusting the Volume

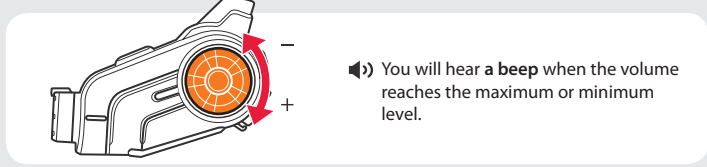

Checking the Battery Level

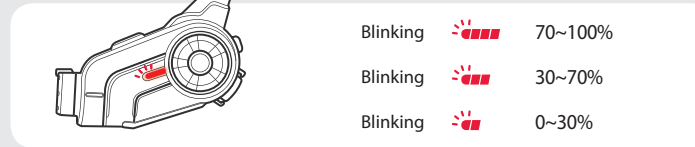

Turn on the headset and check the battery level via the Status LED.

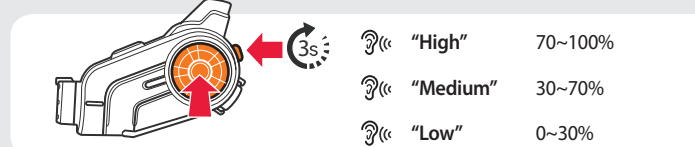

Or, press and hold the Jog Dial and the Phone Button for 3 more seconds when the headset turns on. You will hear a triple beep and a voice prompt.

Charging the Battery

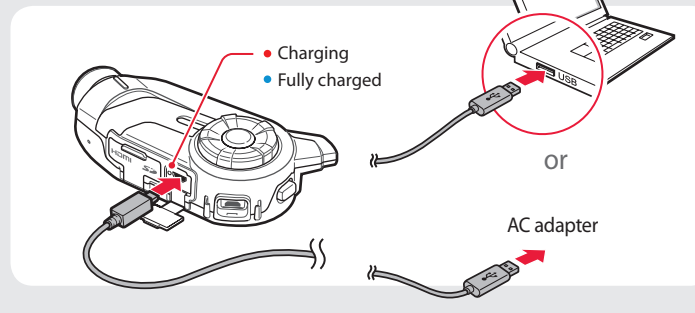

PAIRING

Pairing with Mobile Devices - Phone, Music



"Phone pairing"

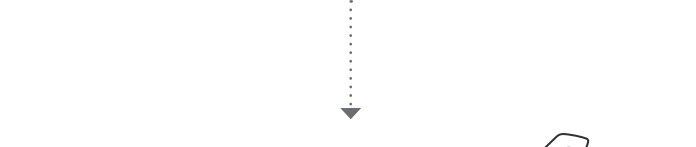

"Your headset is paired"

Using Phone Features

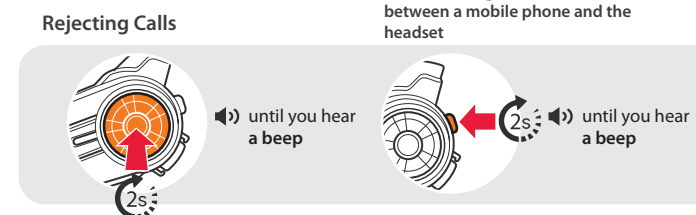

Making Calls



Using the Speed Dial

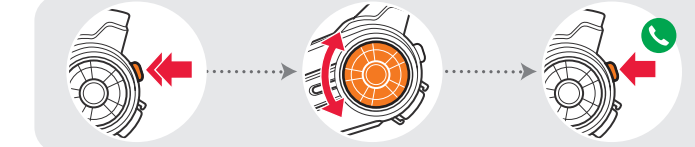

- You will hear a beep.
- "Speed dial"
- Voice Menu**
- Last number redial
 - Speed dial 1
 - Speed dial 2
 - Speed dial 3
 - Cancel

Listening to Music

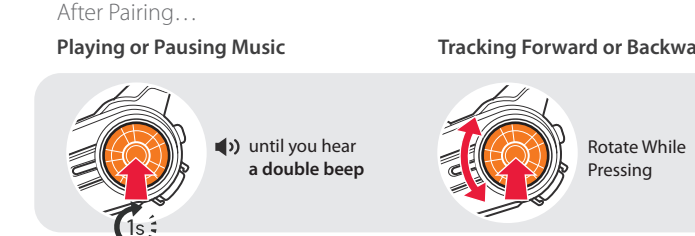

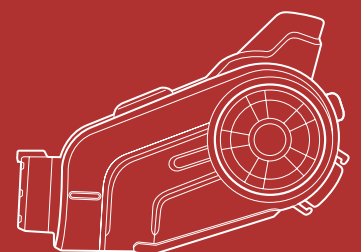

INTERCOM

Pairing with Other Headsets

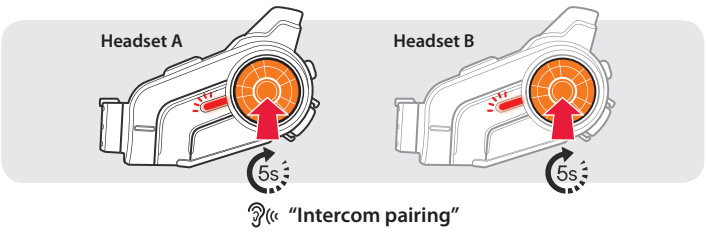

Using the Intercom

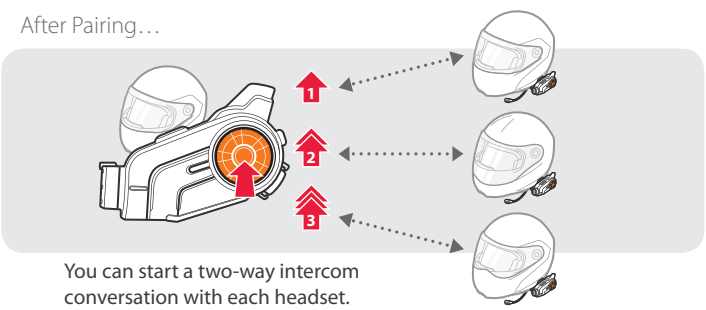

CAMERA

Turning On/Off the Camera

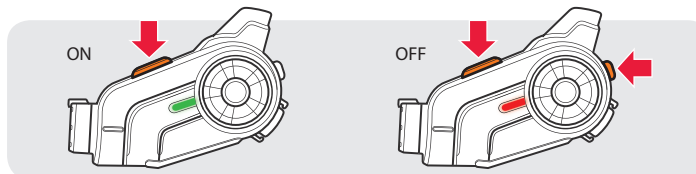

Recording Videos

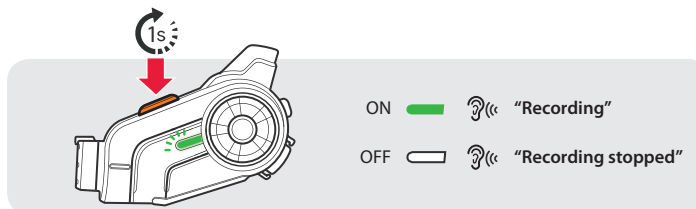

Taking Photos

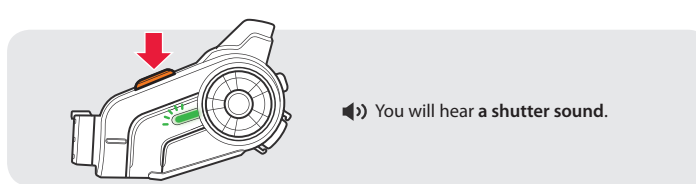

Tagging Videos

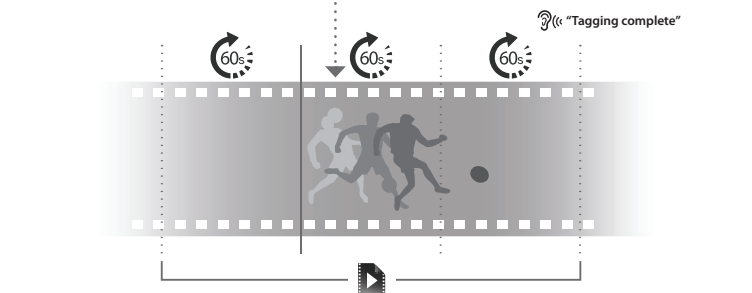
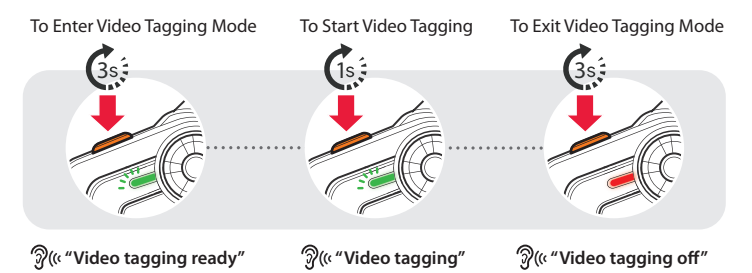

RADIO

Turning On/Off the FM Radio



Seeking Stations

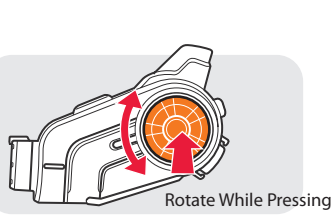

Listening to Preset Stations

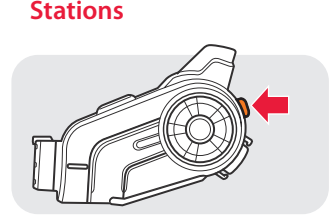

Saving or Deleting Stations

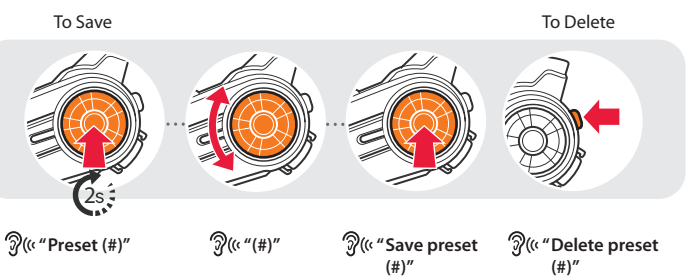

SETTING

Method1) Using the headset

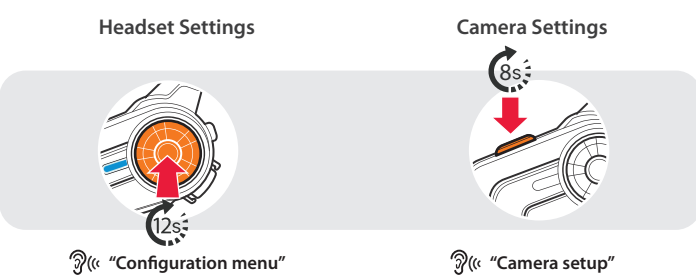

Method2) Using the Sena Device Manager

Connect the headset to your computer via a USB cable. Launch the Sena Device Manager and click **DEVICE SETTING** to configure the headset settings.

For details about downloading the Sena Device Manager, refer to the leaflet included in the package.

Method3) Using the Sena Smartphone App

1. On your smartphone, download the Sena Smartphone App for Android or iPhone from Google Play or App Store. Refer to www.sena.com/app for more details.
2. Pair your smartphone with the headset.
3. Run the Sena Smartphone App. Swipe the screen to the right and tap **Setting** to configure the headset settings.

TROUBLESHOOTING

Factory Reset

If you want to restore the 10C to factory default settings, press and hold the **Phone Button** for 12 seconds. Tap the **Jog Dial**. The headset automatically restores the default settings and turns off.

Fault Reset

If the 10C is not working properly for any reason, push the pin-hole reset button located on the back of the headset.

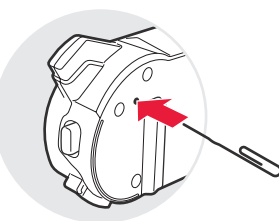

Sena Technologies, Inc.

www.sena.com

www.facebook.com/senablueooth

Customer Support: support.sena.com

Tel (North America): 408-300-9797 **E-mail:** support@sena.com